

BILL OF MATERIALS		
NO.	AMT	DESCRIPTION

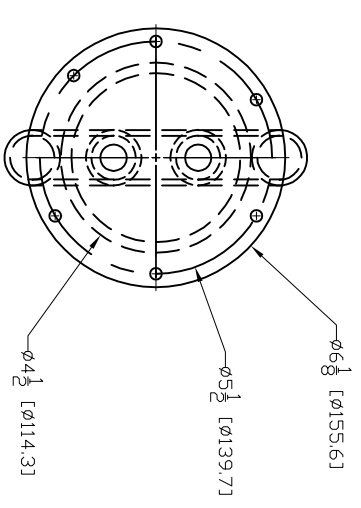
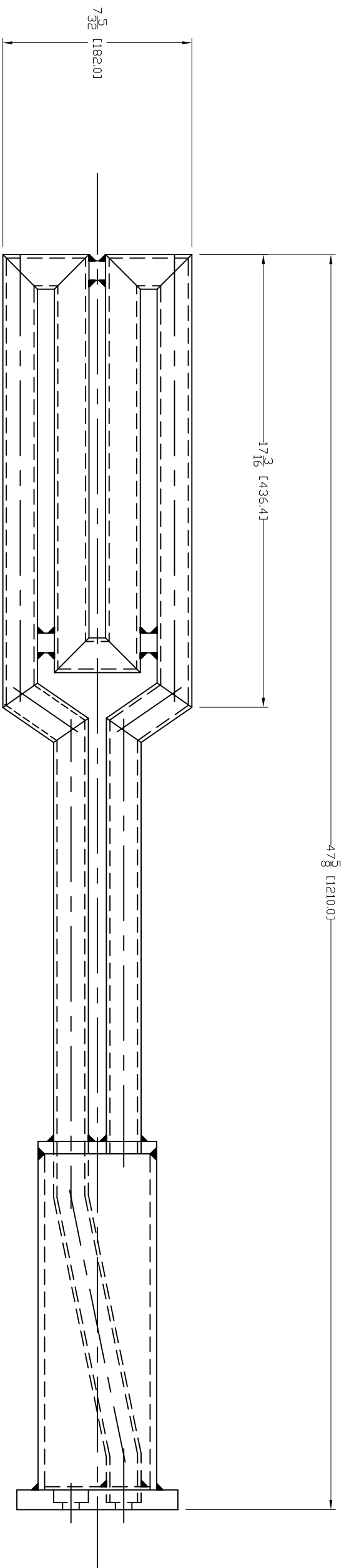

NOTES:

1. COMPLETED PADDLE TO BE STATIC PRESSURE TESTED AT 240 PSI FOR 8 HOURS
2. PADDLE MUST BE CONCENTRIC ABOUT C/L AT ALL POINTS TO WITHIN 1.5MM T.I.R.
3. METRIC DIMENSIONS IN [PARENTHESES]
4. ALL WELDING TO BE CERTIFIED
5. BILL OF MATERIAL ITEMS ARE IN METRIC

DATE	REVISION DESCRIPTION
	REVISION HISTORY

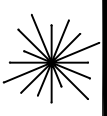
 Resources Unlimited Inc. P.O. Box 173 Carleton, MI 48117	
TITLE	STANDARD STIRRER PADDLE
NAME	E. P. KEHDE
DATE	12-23-06
PAGE	1
OF	1
PART NO.	FN042501
USED ON	STIRRERS
SCALE	NONE